

Z-Line Low Profile Shelving

RETAIN INSTRUCTIONS FOR FUTURE REFERENCE



ZA7-4824S-4D



ZA7-4824A-4D



**ZA7-4824S-4D with
ZAES-4824D extra shelf**

GENERAL SAFETY INFORMATION

Some parts may have sharp edges. CARE must be taken when handling various pieces to avoid injury. For safety, wear a pair of work gloves when assembling or performing any maintenance on units.

LIMITED WARRANTY

Tennsco warrants goods purchased hereunder to be free of defects in materials and workmanship for a period of one (1) year from the date of shipment, hereunder. This warranty shall not apply in the event goods are damaged as a result of misuse, abuse, neglect, accident, improper application, modification or repair by persons not authorized by Seller, where goods are damaged during shipment, or where the date stamps on the goods have been defaced, modified or removed. UNLESS CONSIDERED UNENFORCEABLE OR UNLAWFUL UNDER APPLICABLE LAW:

- a. ALL IMPLIED WARRANTIES, INCLUDING BUT NOT LIMITED TO WARRANTIES OR MERCHANTABILITY AND FITNESS FOR A PARTICULAR PURPOSE ARE HEREBY EXCLUDED;
- b. BUYERS REMEDY, IF ANY, FOR ANY DEFECTIVE GOODS SHALL BE LIMITED TO A REFUND BY SELLER OR REPLACEMENT OF THE GOODS AT SELLER'S OPTION, AND SHALL IN NO EVENT INCLUDE DAMAGES OF ANY KIND, WHETHER INCIDENTAL, CONSEQUENTIAL OR OTHERWISE.

NO GOODS ACCEPTED FOR RETURN WITHOUT PRIOR APPROVAL. Seller shall have the right to inspect any goods claimed to be defective at Buyers place of business or require Buyer to return the goods to Seller for inspection on Seller's premises. Transportation charges covering returned goods will be borne by Seller only if such goods are proven to be defective, are covered by this warranty and are returned within the warranty period stated above.



PROUDLY MADE IN THE U.S.A.

Tennsco LLC., Dickson, TN 37056-1888 • (866) 446-8686

ASSEMBLY OF LOW PROFILE SHELVING

Tools Needed: A rubber mallet for seating the shelf supports into the uprights.

Two people are recommended for assembly. Approximate assembly time: 20-30 minutes per section.

1. The reference numbers used throughout this sheet refer to the illustration on the back cover. This is to help you to identify the various parts as they are mentioned.
2. Depending upon whether you ordered a single unit or an adder unit, you may have one or both of the styles of upright shown. A single unit will use EUR posts for all four uprights, as show below in Figure A. If you plan on installing an adder unit, you should build your starter unit with two ZTP posts on one end which will join with the adder as shown in Figure B.

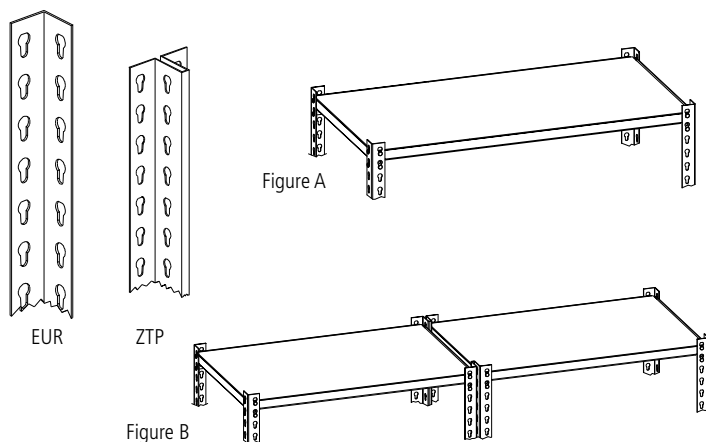

3. With the help from an associate, or using a wall for support, connect two EUR uprights (Ref. No. 1) using two front-to-back supports (Ref. No. 3), one at the top and one near the bottom (leaving the bottom-most keyhole slot empty). Be sure the front-to-back supports are fully seated in the keyhole slots as shown.

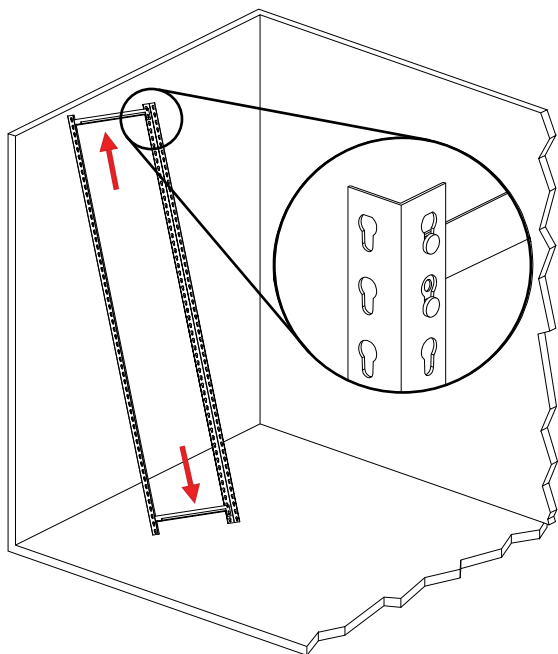

NOTE: The uprights must be positioned so that the narrow part of the slots is toward the floor, as shown.

4. Place a third front-to-back end support in the middle slots of the two uprights. This forms one end of the shelving unit.

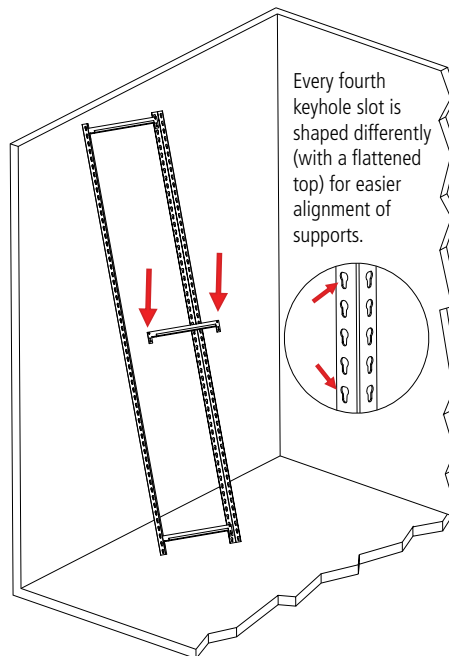

NOTE: There will be only three front-to-back end supports per unit end, as shown. These are used for rigidity and are not needed at every shelf level.

5. Repeat steps 3 and 4 to construct a second set of unit ends. If you are planning to install an adder unit, this second end should consist of ZTP uprights (Ref. No. 2) to act as an intermediate assembly.

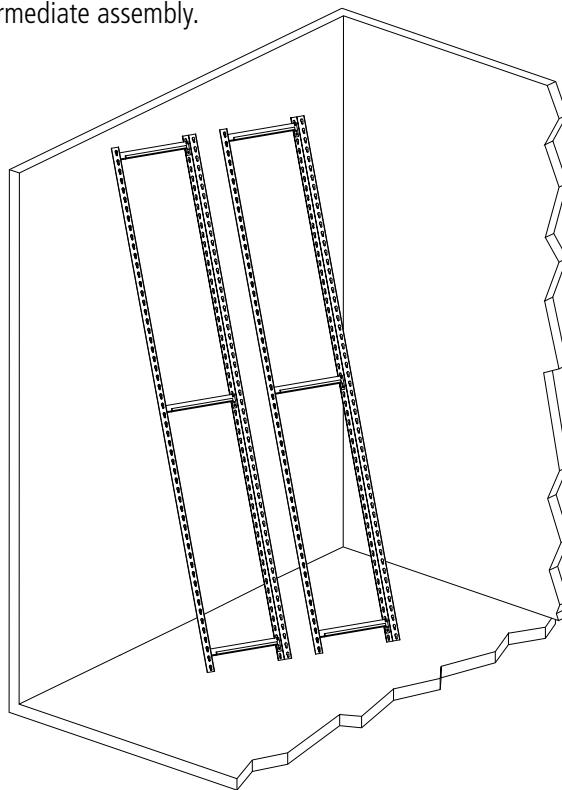

6. With the help of an associate, connect the two unit ends with left-to-right shelf supports (Ref. No. 3). Be sure the shelf support is oriented as show below.

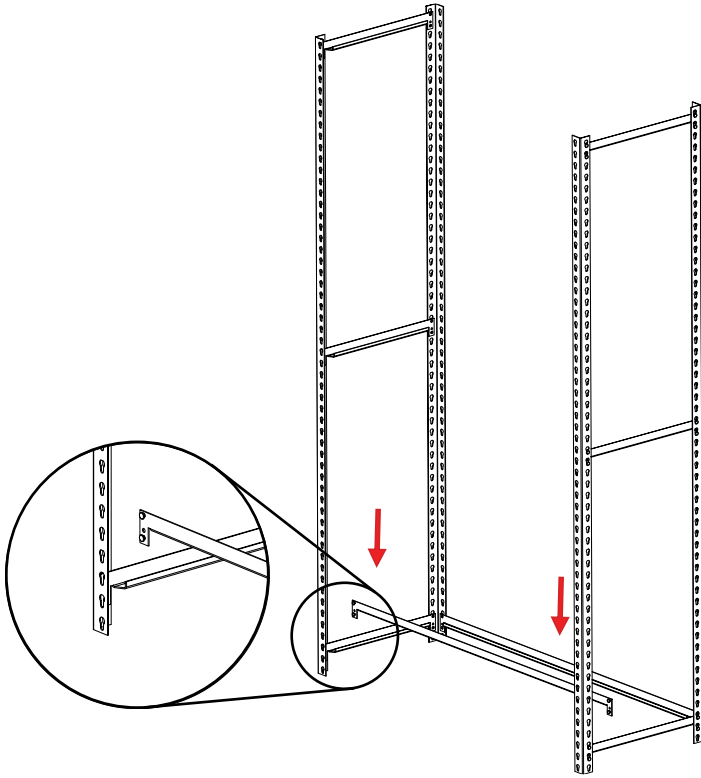

7. Attach the remaining shelf supports at the desired shelf levels.

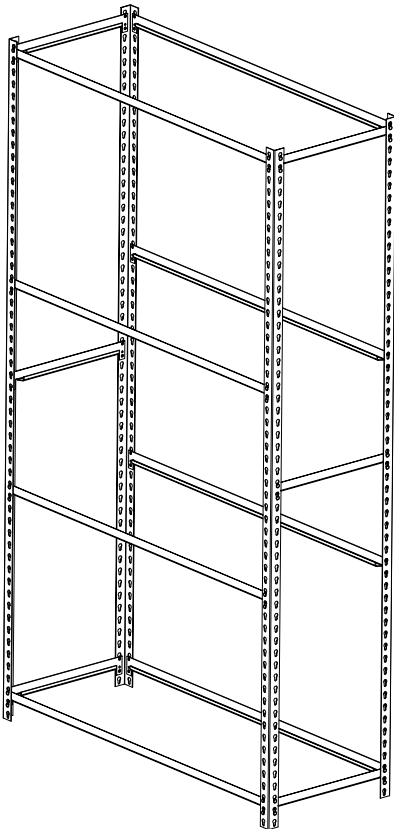

8. If particle board or wire decking was purchased, place the decking on each shelving level. Particleboard decking should fit flush inside the shelf supports, while wiring decking will sit slightly below the shelf support edges. If you have purchased a single unit, your shelving unit is now complete. For adder units, proceed to step 9.

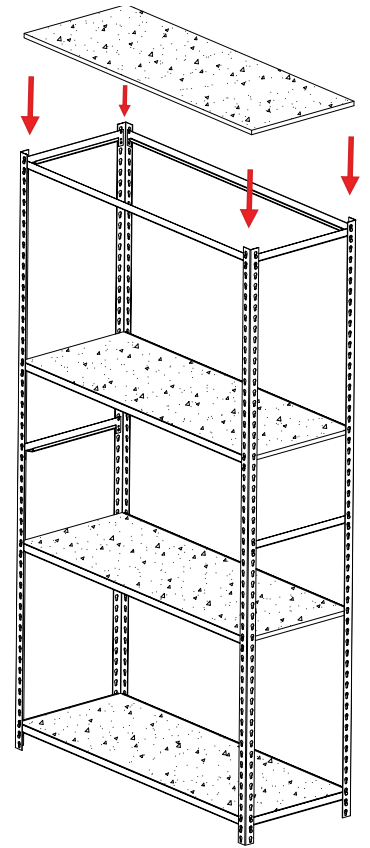

9. If joining more than one unit together, your original unit should have been assembled with ZTP uprights on one end, as described in step 5. Simply continue adding shelf supports and uprights to complete your additional units.

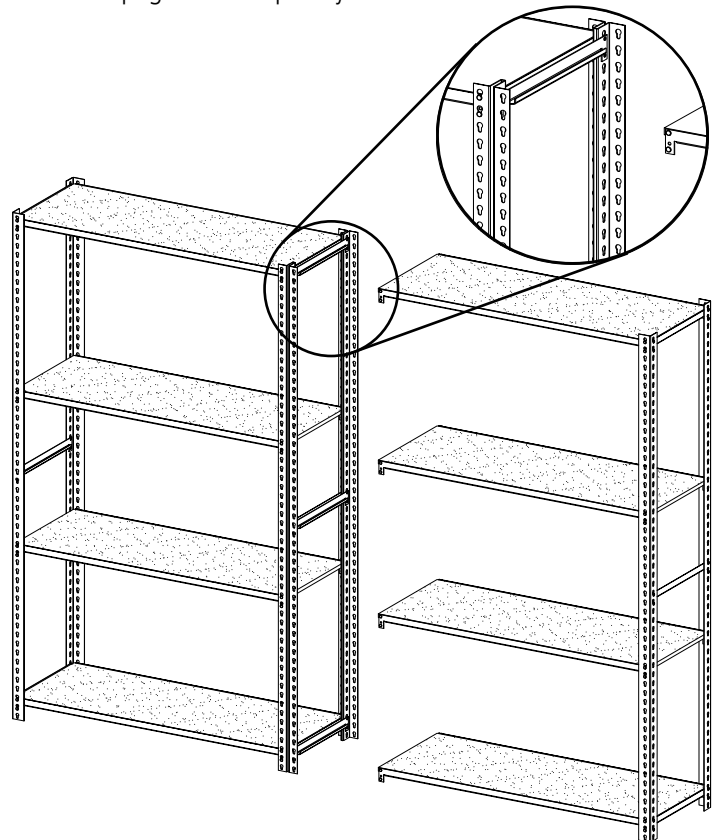

REPLACEMENT PARTS

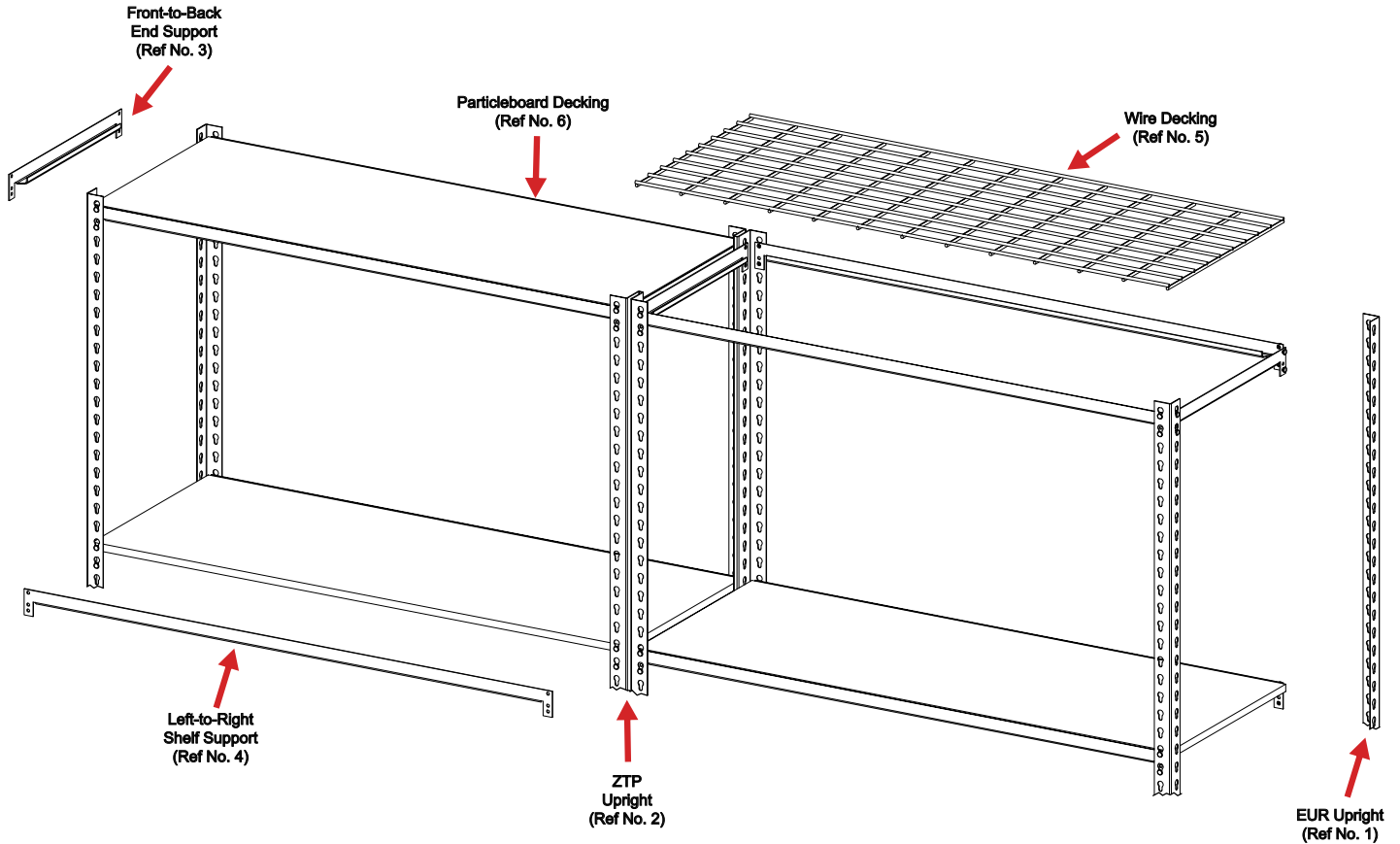

REF. NO.	DESCRIPTION	PART NO.	STARTERS	QTY.		*OPTIONAL EXTRA SHELF
				ADDERS		
1	Angle Post (single or starter units only)	EUR-hh	4	--	--	--
2	"T" Post (adders units only)	ZTP-hh	--	2	--	--
3	Front-to-Back End Support	DRS-dd14	6	3	--	--
4	Left-to-Right Shelf Support	DRS-ww14	8	8	--	*2
5	Particleboard Decking	OR PB-wwdd	4	4	--	*1
6	Optional Wire Decking	ZWD-wwdd	4	4	--	*1

*Additional shelf must be purchased separately. Unit comes standard with four shelf levels with particleboard decking.

NOTE: Additional hardware may be included for replacement purposes.

Tennsco makes every effort to ensure that all units ship complete with all parts and arrive undamaged. However, should your unit contain missing or damaged parts, please contact your purchase location.